

# Comparison of Backpropagation Control Algorithm with P-Q Theory for Power Quality Improvement Using DSTATCOM Under Steady State Condition

Pavan Kumar Thatikonda<sup>1,\*</sup>, P. Lokender Reddy<sup>2</sup>

## Abstract

*Providing consumers with high-quality power is the distribution operator's primary goal. Distribution static compensator (DSTATCOM), dynamic voltage restorer (DVR), and unified power quality conditioner (UPQC) are examples of power converter-based custom power devices (CPDs) that are well-known for enhancing the distribution system's power quality. In order to lessen source-side supply power harmonics, DSTATCOM is taken into consideration in this work. Any bespoke power device's performance is heavily dependent on the control algorithm utilized for the gating pulse generating method and reference current estimate. In this study, a backpropagation-based control method based on artificial neural network (ANN) principles is used to recover the fundamental weighted values of active and reactive power components from distorted load currents. Even in the presence of nonlinear and unbalanced loading conditions, this intelligent control strategy allows for the precise separation of fundamental and harmonic components. The reference source currents needed for compensation are then estimated using the derived basic components. The basic weighted values of the active and reactive power components of load currents, which are necessary for estimating reference source currents, are extracted in the current work using a control technique based on back propagation. To produce switching pulses for the DSTATCOM, an adaptive hysteresis band current control technique is proposed. By using both combinations of techniques, the DSTATCOM is developed and simulated under steady state conditions. The performance of proposed back propagation control algorithm in a three-phase distribution system under non-linear loads is compared with conventional P-Q theory and superiority of the proposed algorithm is demonstrated under steady state conditions.*

**Keywords:** CPDs, DSTATCOM, back propagation, P-Q theory, artificial neural network (ANN)

### \*Author for Correspondence

Pavan Kumar Thatikonda

E-mail: pavan.27101987@gmail.com

<sup>1</sup>Lecturer, Department of Electrical and Electronics Engineering, Department of Technical Education, Hyderabad, Telangana, India

<sup>2</sup>Assistant Professor, Department of Electrical Engineering, Osmania University, Hyderabad, Telangana, India

Received Date: November 06, 2025

Accepted Date: November 28, 2025

Published Date: March 19, 2026

**Citation:** Pavan Kumar Thatikonda, P. Lokender Reddy. Comparison of Backpropagation Control Algorithm with P-Q Theory for Power Quality Improvement Using DSTATCOM Under Steady State Condition. International Journal of Electrical Power System and Technology. 2026; 12(1): 25–34p.

## INTRODUCTION

In the contemporary era, the primary concern in electrical power systems is power quality, wherein customers consistently prioritize reliability, optimal power cost, uninterrupted supply, and power quality. Consequently, there is a need for the implementation of power quality enhancement devices in the local distribution system [1–4]. Within this project, a Distribution Static Compensator (DSTATCOM), a Flexible AC Transmission System (FACTS) device, is used to enhance power quality in the distribution network. The control mechanism for the DSTATCOM involves the application of the backpropagation (BP) algorithm [5, 6]. This method is considered one of the most effective solutions for extracting

reference currents. Furthermore, an adaptive hysteresis band controller is integrated into this project to generate triggering pulses for the DSTATCOM based on these currents. The proposed combination of the backpropagation control algorithm and adaptive hysteresis band controller offers innovative solutions to power quality issues, including the mitigation of harmonics, voltage sag, voltage swell, voltage fluctuations, poor power factor, voltage mismatches, and load balancing [7–9]. The research also includes a comparative analysis of the proposed backpropagation control algorithm in a three-phase distribution system under nonlinear loads against the conventional P-Q theory [10].

**METHODOLOGY**

This chapter describes the enhancement of power quality through the implementation of a DSTATCOM, carried out using MATLAB/Simulink software (version 2016a). The study involves a comparison between the backpropagation control algorithm and the P-Q theory for improving power quality with a DSTATCOM under steady-state conditions. Two distinct controllers are employed to effectively control the DSTATCOM. The first uses the backpropagation algorithm for generating reference signals, while the second employs the variable hysteresis control method to produce absolute switching pulses. The simulation results confirm the satisfactory operation of the DSTATCOM with these controllers.

**CONTROL ALGORITHMS AND CONTROLLER**

**P-Q Theory Control Algorithm**

Figure 1 shows the P-Q theory control algorithm, also known as Instantaneous Reactive Power Theory (IRPT), which is used to control the DSTATCOM and generate reference quantities and gate pulses for the VSC. To extract the reference current, the DSTATCOM performs according to gate pulses provided by the control algorithm. These currents are used to accomplish load management when the distribution system grid voltages, which feed nonlinear loads, are sinusoidal yet polluted.

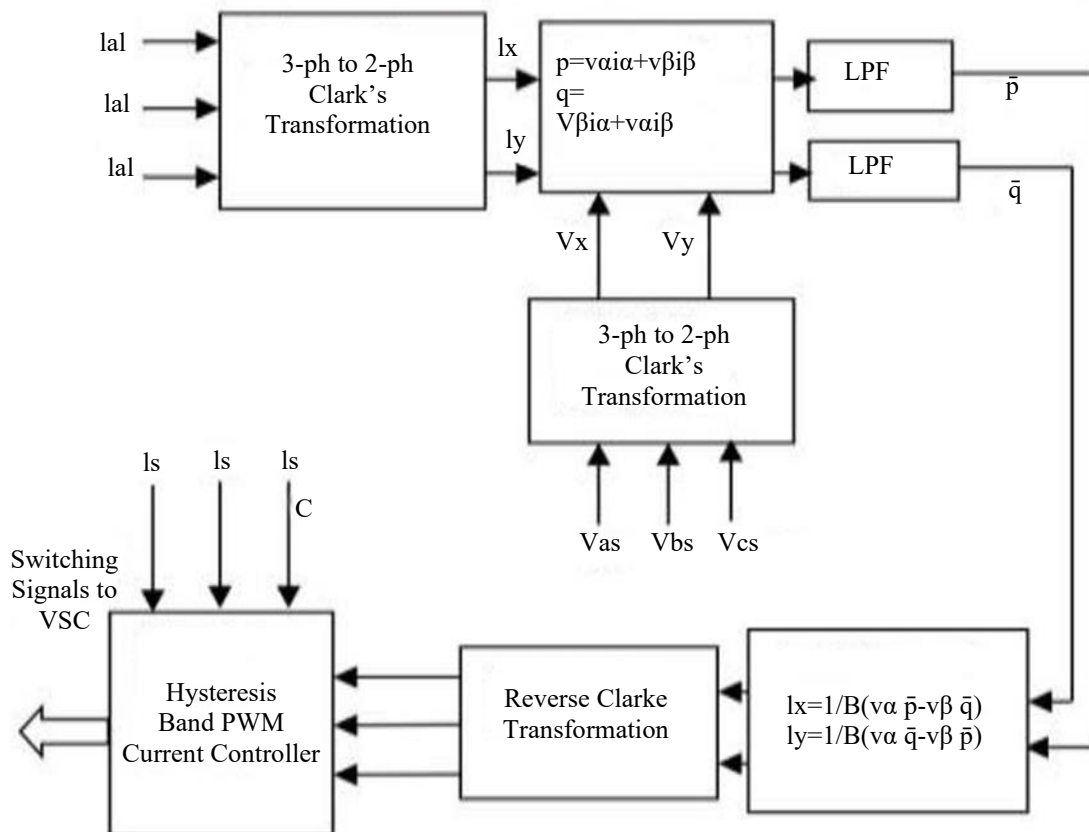

**Figure 1.** P-Q theory control algorithm.

### Back Propagation Control Algorithm

The DSTATCOM is controlled using a two-stage operation. First, the backpropagation algorithm, as has been shown in Figure 2, is proposed for adjusting the weight components of active and reactive powers from the error elements such that the reference signals of the supply current are produced. Second, an adaptive hysteresis controller is preferred for the formation of the triggering pulses to the DSTATCOM. The backpropagation algorithm comprises three parts: a feed-forward operation to produce outputs, a feedback activity to propagate the error signal back to the input, and adjustment of the new weights.

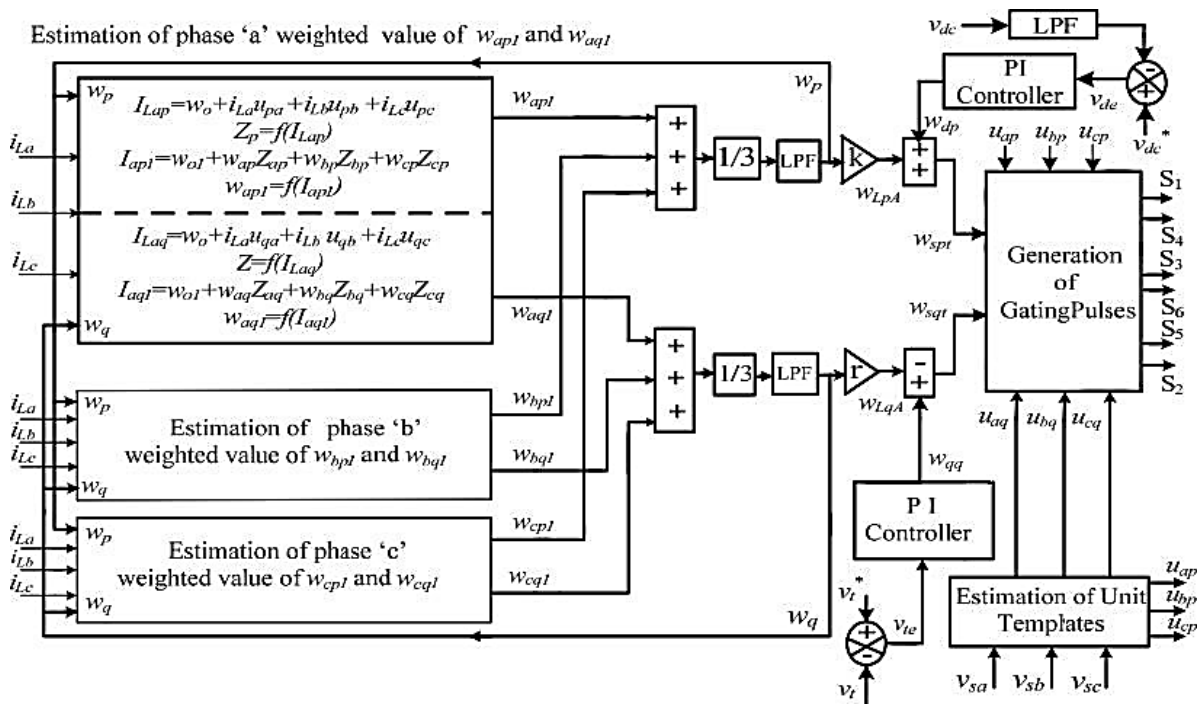

Figure 2. Backpropagation control algorithms.

### Adaptive Hysteresis Controller

The adaptive hysteresis band (HB)-based controller is an acceptable solution for all voltage source converter applications in active filters, grid-connected networks, permanent magnet systems, etc. The regular hysteresis band (RHB) has numerous undesirable characteristics; for example, audible noise is produced due to unsymmetrical switching frequency, and input filter design is difficult. Figure 3 shows a traditional hysteresis band controller.

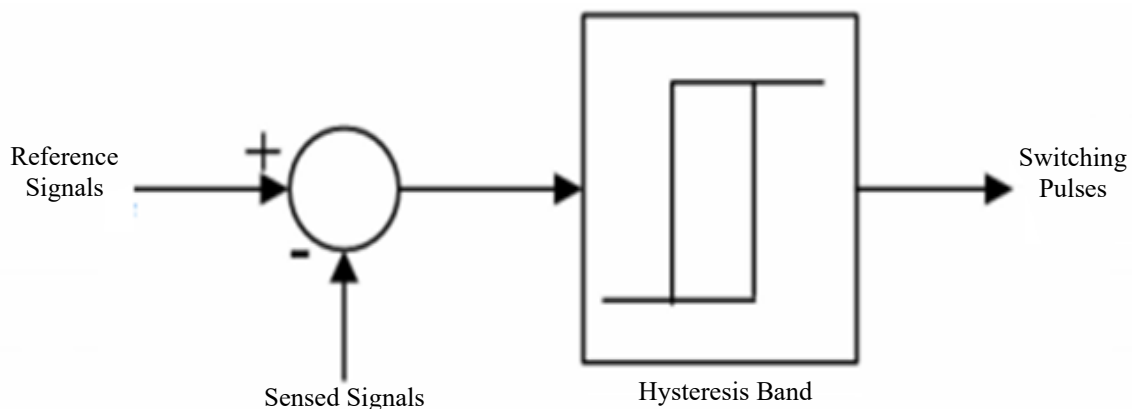
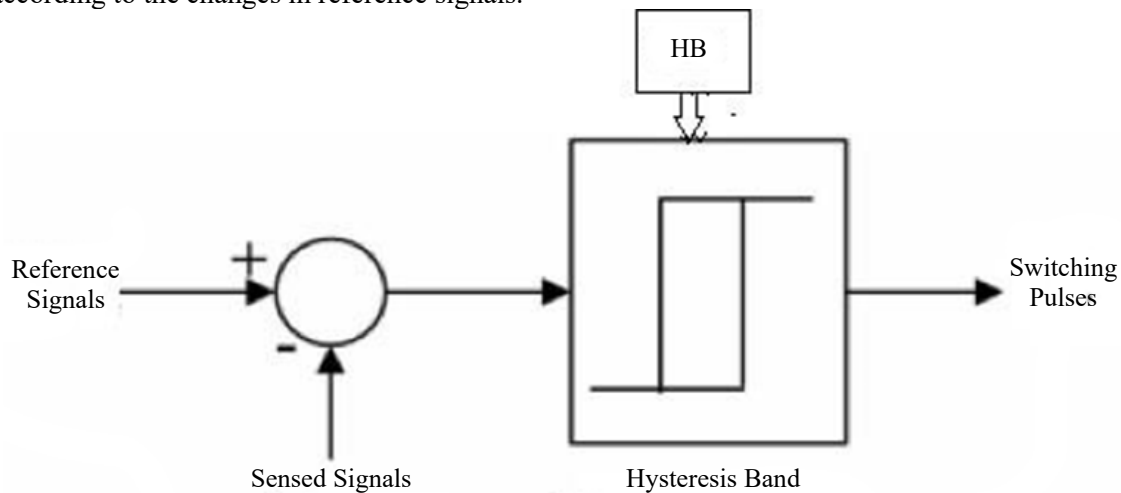

Figure 3. Regular hysteresis band controller.

To overcome these complexities in the traditional hysteresis controller, the variable hysteresis band method is proposed, as shown in Figures 4 and 5. It comprises a variable hysteresis band that varies according to the changes in reference signals.



**Figure 4.** Variable hysteresis band block diagram.

The hysteresis band (HB) is estimated from the following numerical formula:

$$HB = \left\{ \frac{0.125 \cdot V_{dc}}{f_c L} \left[ 1 - \frac{4L^2}{V_{dc}^2} \left( \frac{v_s}{L} + \frac{di_{ca}^*}{dt} \right)^2 \right] \right\}$$

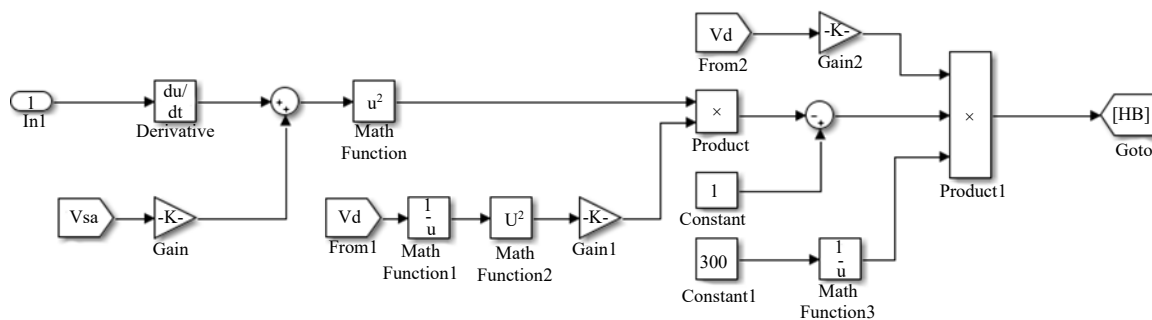

**Figure 5.** Calculation of HB.

The HB depends on the voltage of the DC link and the reference signal’s slope, so the hysteresis band changes according to these values.

The sensed and reference signals are differentiated and fed to the variable hysteresis band controller to produce the triggering pulses required to control the DSTATCOM to improve power quality.

**SIMULINK MODELS WITH SIMULATION PARAMETERS**

The simulation of a three-phase distribution network is modeled in MATLAB/Simulink (version 2016a) with a variable-step auto solver. In this chapter, the simulations with and without the DSTATCOM and specified algorithms connected to the distribution networks are modeled, and the simulation results are discussed.

**With DSTATCOM of P-Q Method**

The DSTATCOM is connected to the three-phase distribution network along with the P-Q method control algorithm, which regulates the gate pulses to the DSTATCOM such that the DSTATCOM operates – that is, sending or receiving reactive power flow with the proposed system. Figure 6 represents

the simulation model of a three-phase distributed system with a DSTATCOM. Here, from the common coupling point, the inductor is coupled in shunt, followed by a universal bridge block that acts as a voltage source rectifier.

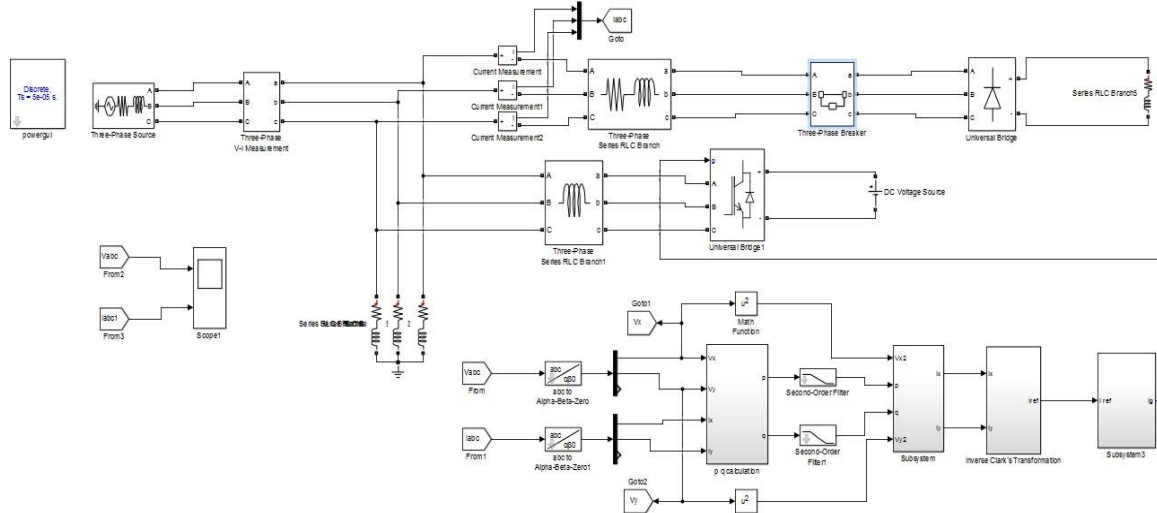

**Figure 6.** Simulation model of a three-phase distribution system with a DSTATCOM by the P-Q method.

### With DSTATCOM of Back Propagation Algorithm

The DSTATCOM is connected to the three-phase distribution network with the backpropagation control algorithm, which regulates the gate pulses to the DSTATCOM such that the DSTATCOM operates – that is, sending or receiving reactive power flow with the proposed system. Figure 7 represents the simulation model of a three-phase distributed system with a DSTATCOM. Here, from the common coupling point, the inductor is coupled in shunt, followed by a universal bridge block that acts as a voltage source rectifier, followed by a DC capacitor that acts as a storage element.

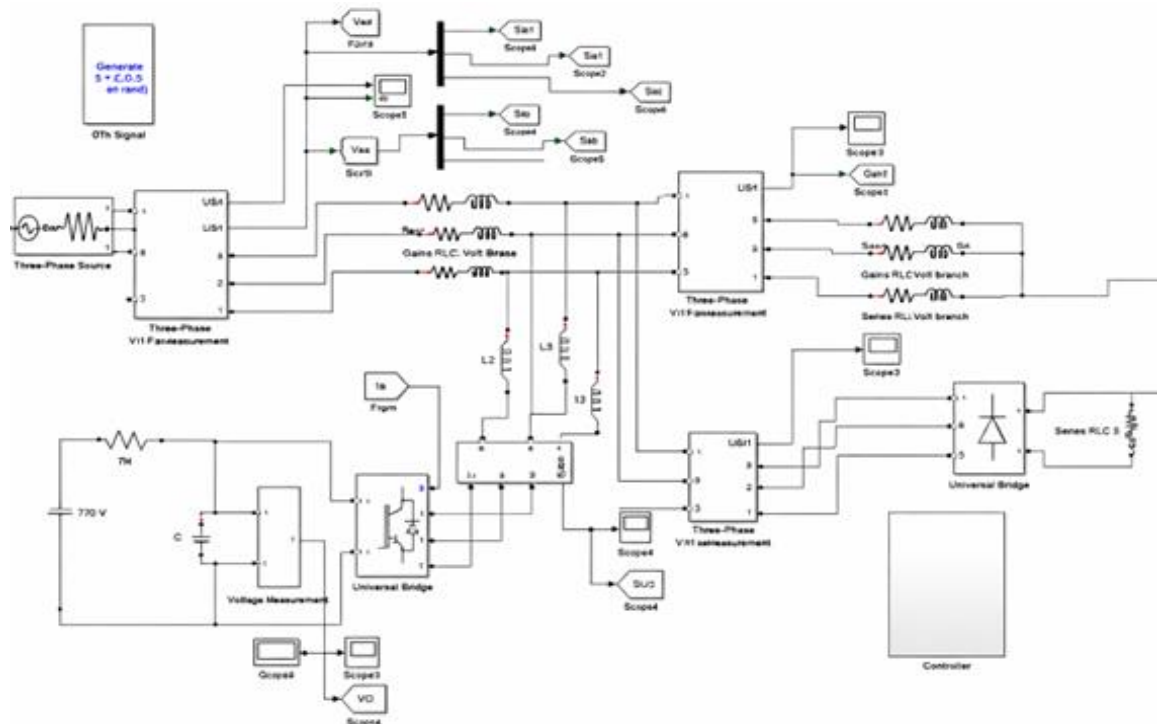

**Figure 7.** Simulation model of a three-phase distribution system with a DSTATCOM.

### Variable Hysteresis Band Simulink Model

The variable hysteresis controller is employed for switching pulse generation. In this method, the hysteresis band (HB) is varied according to the changes in the reference current’s slope, as discussed in chapter 4. The Simulink model for this controller is shown in Figure 8. For generating pulses, a simple MATLAB function is used based on the HB minimum and maximum values.

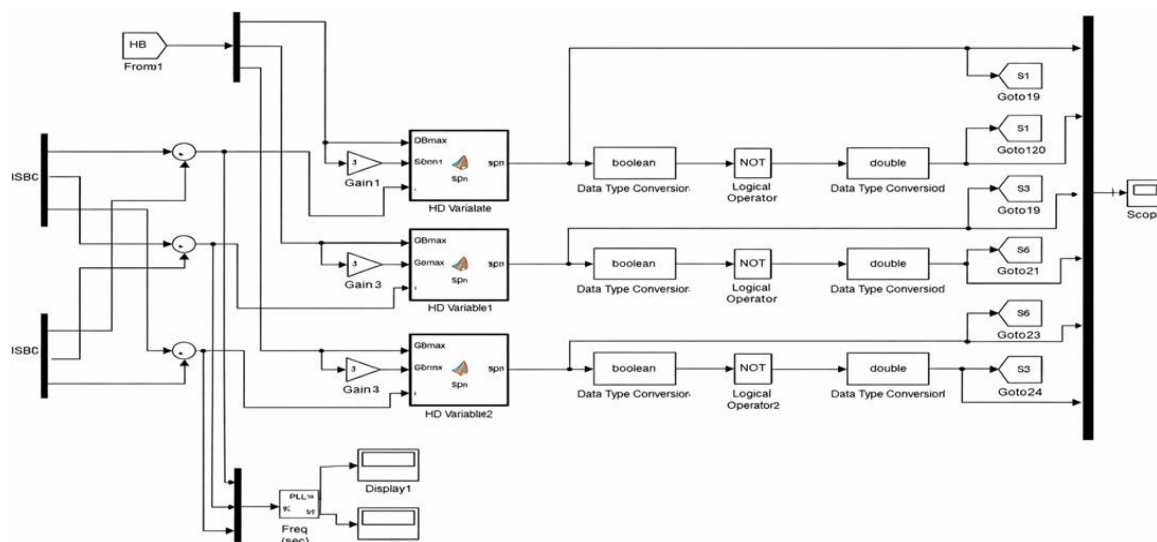

**Figure 8.** Simulink model for a variable hysteresis controller.

After the sensed and reference parameter signals are compared, the HB values are fed to the MATLAB function. Table 1 shows the simulation parameters.

**Table 1.** Simulation parameters for the backpropagation control algorithm and P-Q method.

S. N.	Parameters	Backpropagation control algorithm	P-Q method
1	AC Supply	3-phase, 415V(L-L), 50 HZ	3-phase, 415V(L-L), 50 HZ.
2	Line impedance	$Z = 2 + 3.14 \Omega$	$Z = 2 + 3.14 \Omega$ .
3	Linear load	$R_a = 150 \Omega, L_a = 100\text{mH}$ $R_b = 110 \Omega, L_b = 100\text{mH}$ $R_c = 100 \Omega, L_c = 100\text{mH}$	$R_a = 150 \Omega, L_a = 100 \text{mH}$ . $R_b = 110 \Omega, L_b = 100 \text{mH}$ . $R_c = 100 \Omega, L_c = 100 \text{mH}$ .
4	Non-linear load	3-phase full-wave diode rectifier with RL loads of $10 \Omega, 500 \text{mH}$	3-phase full-wave diode rectifier with RL loads of $10 \Omega, 500 \text{mH}$ .
5	Interfacing inductor	4 mH	4 mH.
6	AC Bus	Gains of PI controller $k_{pt} = 3, k_{it} = 4$ ; Cut off frequency of LP filter $f_c = 10 \text{ Hz}$	–
7	DC Bus	Gains of PI controller $k_{pd} = 3, k_{id} = 0.9$ ; Cut off frequency of LP filter $f_c = 15 \text{ Hz}$	–
8	Input weights	$w_o = 0.4, w_l o = 0.2$	–
9	Larning rate	$\mu = 0.6$	–

### RESULTS AND DISCUSSION

The performance of the DSTATCOM under steady-state conditions is examined in three simulation scenarios: without a DSTATCOM, with a DSTATCOM controlled by P-Q theory, and with a DSTATCOM controlled by the backpropagation control algorithm. These simulations are conducted under both linear and nonlinear loads, where the load remains constant without sudden changes. The

objective is to assess the system's behavior and power quality in each case, considering factors such as voltage stability, harmonic distortion reduction, and power factor regulation.

### Without DSTATCOM

In the initial stage, the DSTATCOM is not connected to the three-phase distribution supply network. Due to the existence of linear and nonlinear loads, various power quality disturbances occur, including distortions in the three-phase voltages and currents of the supply system. In addition, the load currents also exhibit an unbalanced nature and contain harmonics. Figures 9 and 10 show the waveform behavior of various parameters: three-phase supply voltages, supply currents, and nonlinear and linear load currents. It is clear from the waveforms that the supply voltages and currents do not have the same peak value, and a random pattern has appeared. The load currents also have many variations in their peak values.

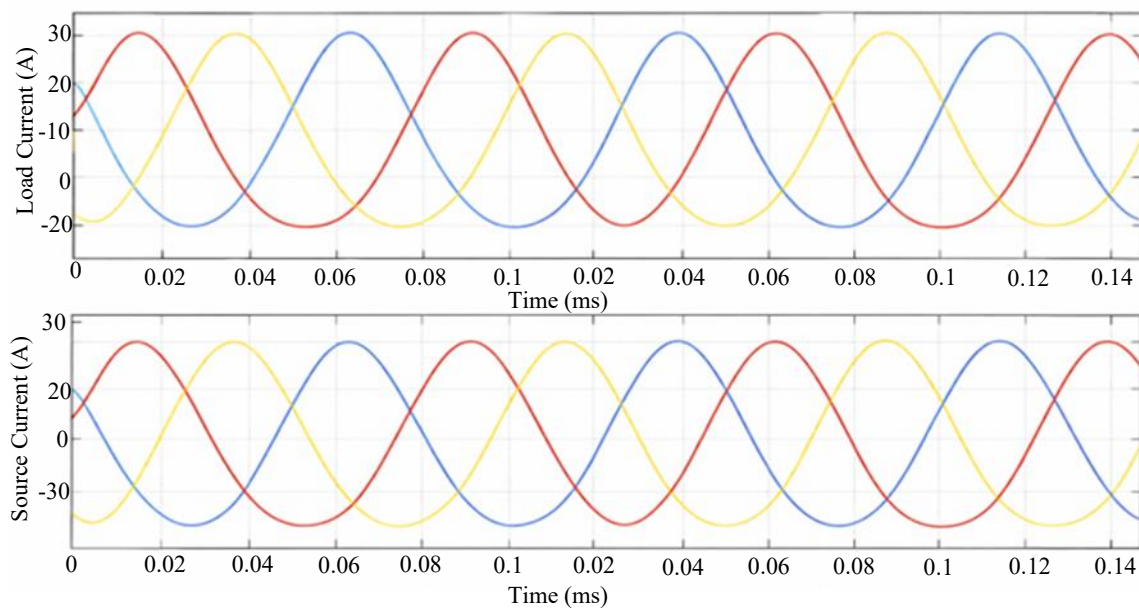

**Figure 9.** Waveforms without a DSTATCOM of (a) source voltages and (b) source currents.

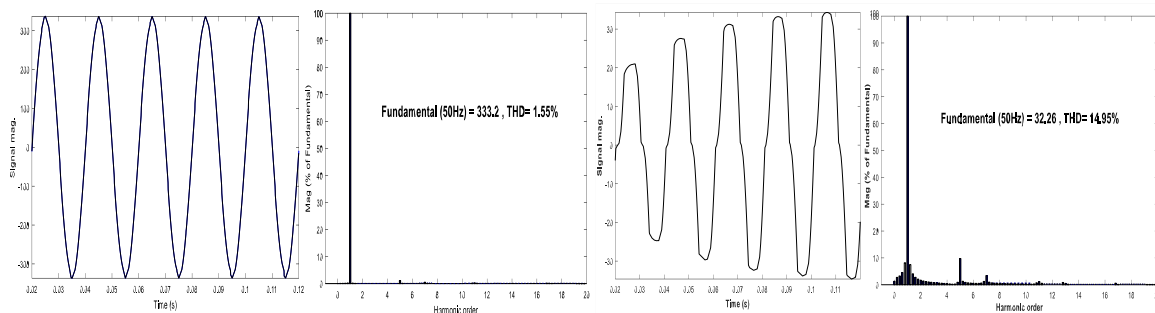
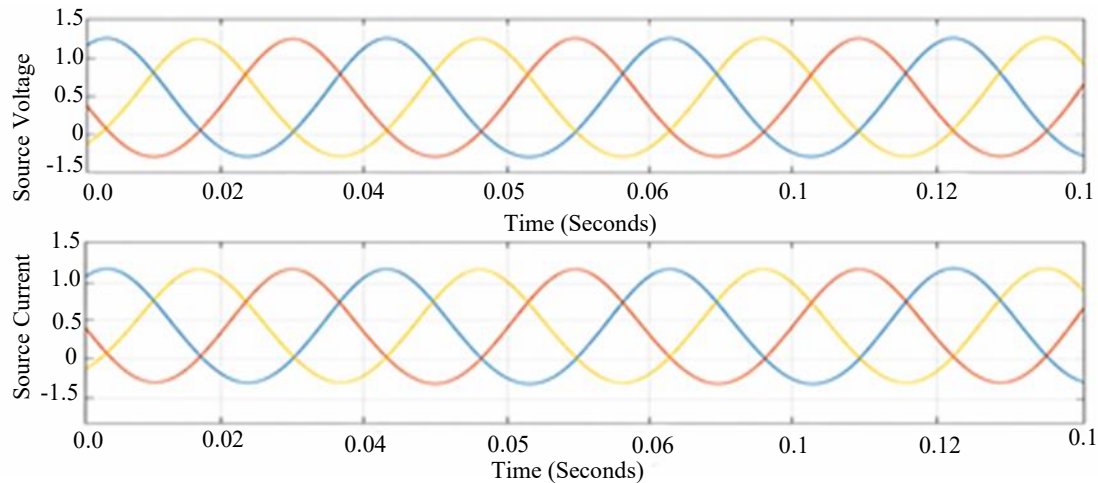

**Figure 10.** FFT analysis of the total harmonic distortion percentage for phase A of (a) source voltage and (b) source current when a DSTATCOM is not connected to the system.

### With DSTATCOM Controlled by P-Q Theory

The DSTATCOM is connected to the proposed system, which includes linear and nonlinear loads. Figure 11 represents the behavior of waveforms of three-phase supply voltages and supply currents. The DSTATCOM supplied reactive power to the specified system based on appropriate switching pulses such that these currents cancel the harmonic current components from the nonlinear load. The simulation results in Figure 11 show that the DSTATCOM supplies reactive power to the line for compensation, which lowers the total harmonic distortion.

The FFT evaluation of the PCC voltage/source voltage and source currents of the three-phase distribution network with a DSTATCOM are shown in Figure 12. The THD values of the source current and PCC voltage for the P-Q method are 7.83% and 1.36%, respectively, after mitigation in phase A of the proposed technique.



**Figure 11.** Waveforms with a DSTATCOM controlled by P-Q theory of (a) source voltages and (b) source currents.

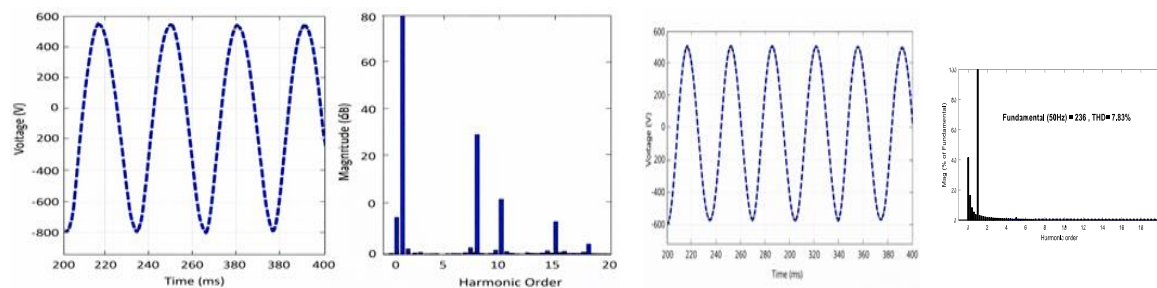

**Figure 12.** FFT analysis with a DSTATCOM controlled by P-Q theory of the total harmonic distortion percentage for phase A of (a) source voltage and (b) source current.

**With DSTATCOM Controlled by the Backpropagation Control Algorithm**

The DSTATCOM is connected to the integrated system featuring both linear and nonlinear loads. In Figure 13, the waveforms of three-phase supply voltages, supply currents, load currents, and DSTATCOM currents are depicted. The DSTATCOM effectively provides reactive power to the system by employing suitable switching pulses. These pulses are strategically designed to nullify the harmonic current components induced by the presence of nonlinear loads.

The simulation results in Figure 13 reveal that the supply voltages and currents exhibit identical peak values with no variations. This implies that the waveforms follow a completely sinusoidal pattern. Additionally, the load currents are observed to be devoid of harmonics.

The percentage of THD is calculated for phase A PCC voltage and source currents. Figure 14 shows the signal parameters and harmonic scales of these parameters; the %THD values of the above parameters are 0.28% and 1.07%, respectively.

The Total Harmonic Distortion (%THD) values for the source voltage and current parameters are analyzed before and after the connection of the DSTATCOM with the proposed algorithms. The comparison presented in Table 2 reveals that when employing the backpropagation control algorithm,

the DSTATCOM achieves the lowest harmonic percentages in comparison to the P-Q theory algorithm. This observation underscores the superior harmonic mitigation capability of the backpropagation control algorithm under steady-state conditions. The demonstrated effectiveness of this algorithm signifies an enhancement in power quality, showcasing its potential to improve overall system performance.

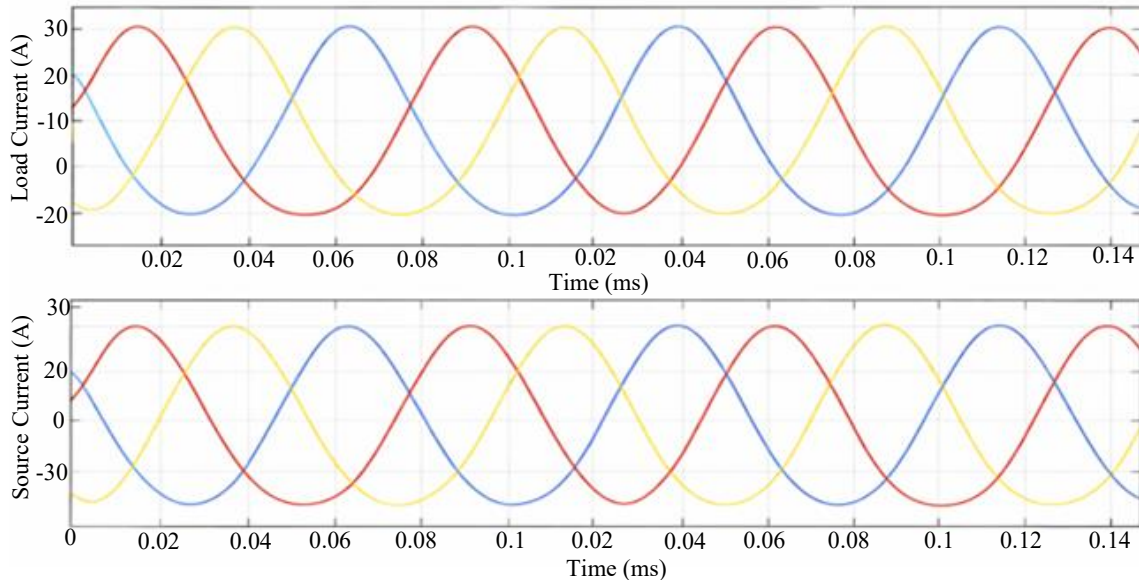

**Figure 13.** Waveforms with a DSTATCOM controlled by the backpropagation control algorithm of (a) PCC voltages and (b) source currents.

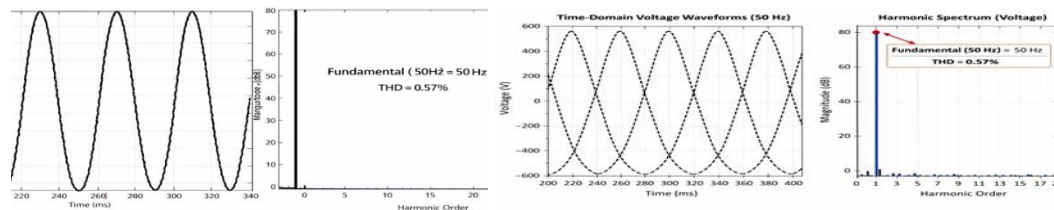

**Figure 14.** FFT analysis with a DSTATCOM controlled by the backpropagation control algorithm of the total harmonic distortion percentage for phase A of (a) PCC voltage and (b) source current.

**Table 2.** Comparison of %THD for P-Q theory and the backpropagation control algorithm under steady-state conditions.

S. N.	Parameters	% THD for without DSTATCOM	% THD for with DSTATCOM	
			P-Q theory	Backpropagation control algorithm
1	PCC voltage	1.55%	1.36%	0.28%
2	Source current	14.95%	7.83%	1.07%

## CONCLUSION

In this work, a three-phase DSTATCOM with a backpropagation control algorithm was developed in MATLAB/Simulink to reduce harmonics at the source side. The proposed algorithm was tested under steady-state conditions with nonlinear loads. The results obtained are compared with the P-Q theory.

It is observed from the results that the proposed backpropagation control algorithm is most effective in load balancing and harmonic reduction when compared with the conventional P-Q theory control algorithm. Based on simulation results, it is concluded that the DSTATCOM and its control algorithm have been found suitable for the compensation of nonlinear loads. Its performance has been found

satisfactory for this application because the extracted reference source currents exactly trace the sensed source currents during the steady-state condition.

The suggested BP algorithm, along with the variable hysteresis controller, successfully improved power quality under steady-state conditions. Hence, the proposed DSTATCOM is very helpful in the modern power system; it protects the source currents from being affected by nonlinear loads.

No structured references were provided. If a references section exists in the manuscript, preserve it verbatim and do not edit it

## REFERENCES

1. Gyugyi L. Active AC power filter. In: Proc IEEE/IAS Annu Meet; 1976. p. 529.
2. Myneni H, Kumar GS, Sreenivasarao D. Adaptive DC-link voltage regulation for DSTATCOM under load variations. In: Proc IEEE Reg 10 Conf (TENCON); 2016. p. 2909–13.
3. Arya SR, Singh B, Chandra A, Al-Haddad K. Power factor correction and zero voltage regulation in distribution system using DSTATCOM. In: Proc IEEE Int Conf Power Electron Drives Energy Syst (PEDES); 2012. p. 1–6.
4. da Silva CH, Pereira RR, da Silva LE, Lambert-Torres G, Bose BK, Ahn SU. A digital PLL scheme for three-phase system using modified synchronous reference frame. *IEEE Trans Ind Electron.* 2010;57(11):3814–21.
5. Pedapenki KK, Gupta SP, Pathak MK. Application of neural networks in power quality. In: Proc Int Conf Soft Comput Tech Implement (ICSCTI); 2015. p. 116–19.
6. Singh B, Arya SR. Back-propagation control algorithm for power quality improvement using DSTATCOM. *IEEE Trans Ind Electron.* 2013;61(3):1204–12.
7. Singh B, Jayaprakash P, Kumar S, Kothari DP. Implementation of neural-network-controlled three-leg VSC and a transformer as three-phase four-wire DSTATCOM. *IEEE Trans Ind Appl.* 2011;47(4):1892–901.
8. Singh B, Adya A, Mittal AP, Gupta JR. Modeling, design and analysis of different controllers for DSTATCOM. In: Proc Joint Int Conf Power Syst Technol IEEE Power India Conf; 2008. p. 1–8.
9. Rohani A, Joorabian M. Modeling and control of DSTATCOM using adaptive hysteresis band current controller in three-phase four-wire distribution systems. In: Proc Int Power Electron Drive Syst Technol Conf (PEDSTC); 2014. p. 291–97.
10. Anuradha E, Naik MB. Power quality improvement by back propagation control algorithm using DSTATCOM. *Int Res J Eng Technol.* 2016;3(3):1474–81.